

EAT

European Audio Team

INSTRUCTIONS FOR SETUP

C-Note Tonearm

Parts List

1. Arm assembly
2. 1.5 mm Allen key for azimuth set screw and cue assembly
3. 2 mm Allen key for VTA adjustment screws
4. Counterweight and additional insert for counterweight
5. Anti-skating sliding mechanism, support rod and thread

Tonearm Assembly

The tonearm includes a combination of cardan and uni pivot bearings, immersed in special damping fluid.

See the next steps to set up your tonearm.

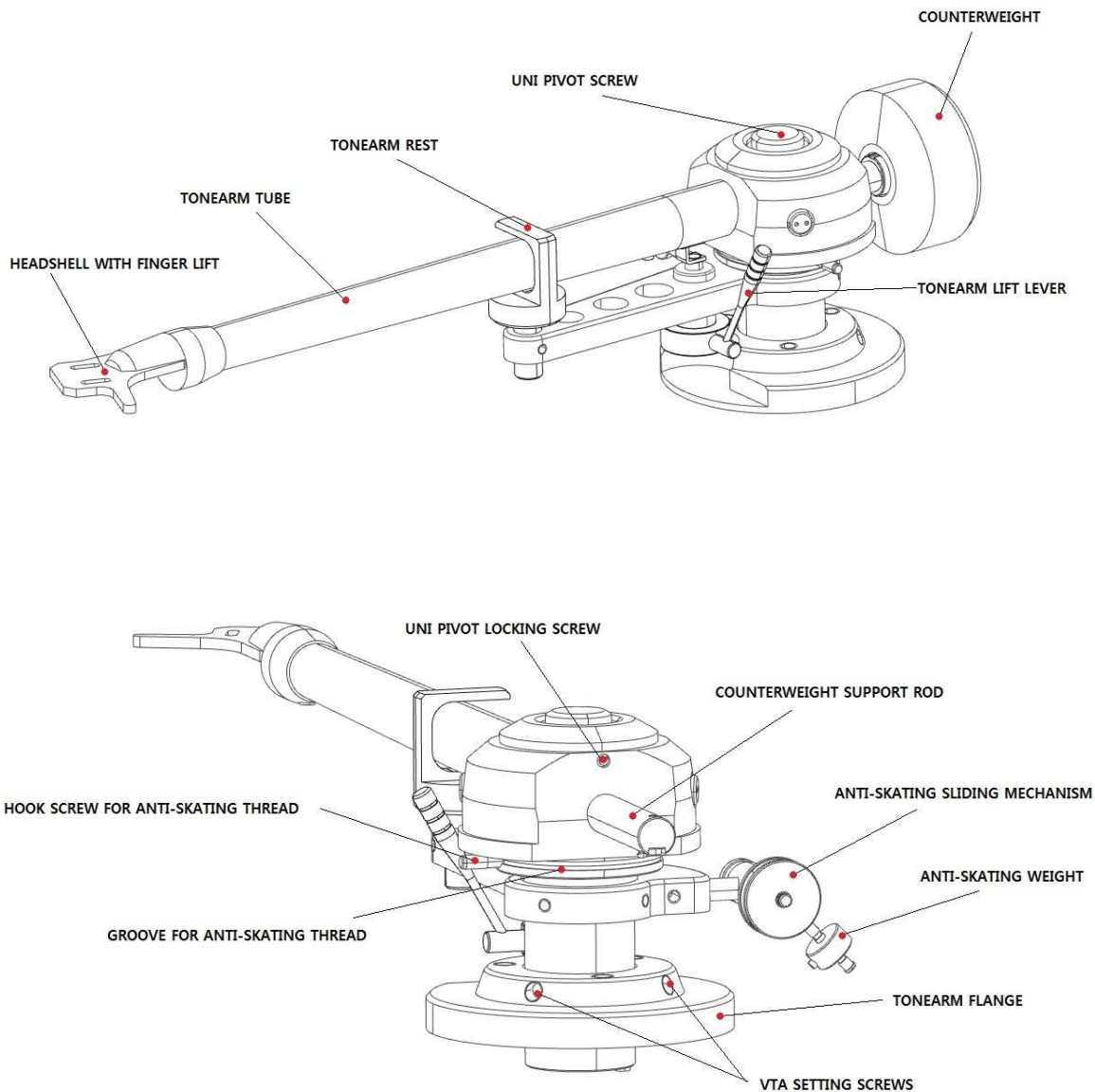

a) Cartridge installation

Install the cartridge into the aluminium headshell, using the appropriate hardware included with your cartridge.

Connect the cartridge as indicated below:

- White left channel L+
- Red right channel R+
- Green right channel R-
- Blue left channel L-

For correct cartridge alignment, use the two-point cartridge alignment protractor provided with your turntable accessories. If unfamiliar with two-point setup, please refer to your dealer.

b) Counterweight assembly

The counterweight has two separate parts:

The first part is the counterweight itself. The second part is an additional insert that enables optimal balancing of heavier cartridges.

The counterweight without the additional insert can balance cartridges **from 5 to 9 g.** (The weight of the counterweight itself is **125 g.**)

The counterweight with the additional insert can balance cartridges **from 8.5 to 13 g.** (The weight of the counterweight with the additional insert is **142 g.**)

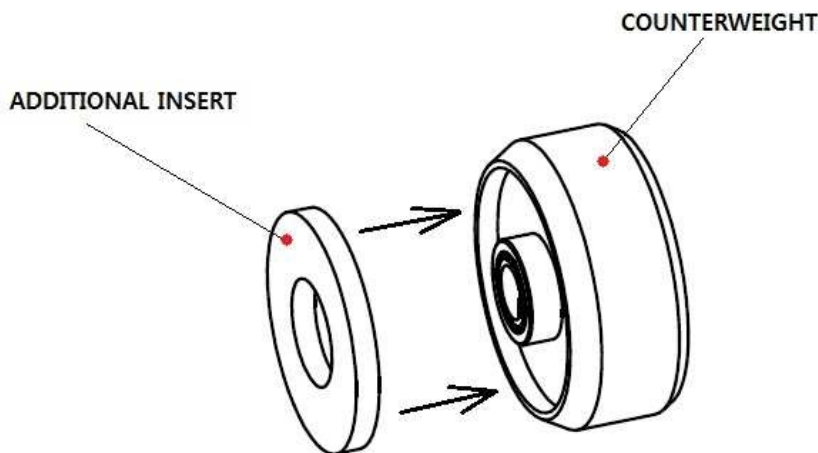

c) Vertical Tracking Force setting (VTF)

Before setting the Vertical Tracking Force, confirm the exact weight of your cartridge. Depending on your cartridge weight, determine whether to use the counterweight with or without the additional insert, in accordance with the specifications above.

Pushing carefully, turn the counterweight onto the rear end of the counterweight support rod as shown in the illustration below. Place the stylus pressure gauge (not supplied) onto the platter. To set the required VTF, lower the tonearm lift lever as indicated in the illustration and place the tip of the stylus on the pressure gauge.

As viewed from the headshell, turning the counterweight counterclockwise (moving it in closer toward the tonearm) increases the VTF, turning clockwise (away from the tonearm) reduces the VTF. Turn the counterweight appropriately until the VTF shown on the pressure gauge matches your cartridge's recommended vertical tracking force specifications.

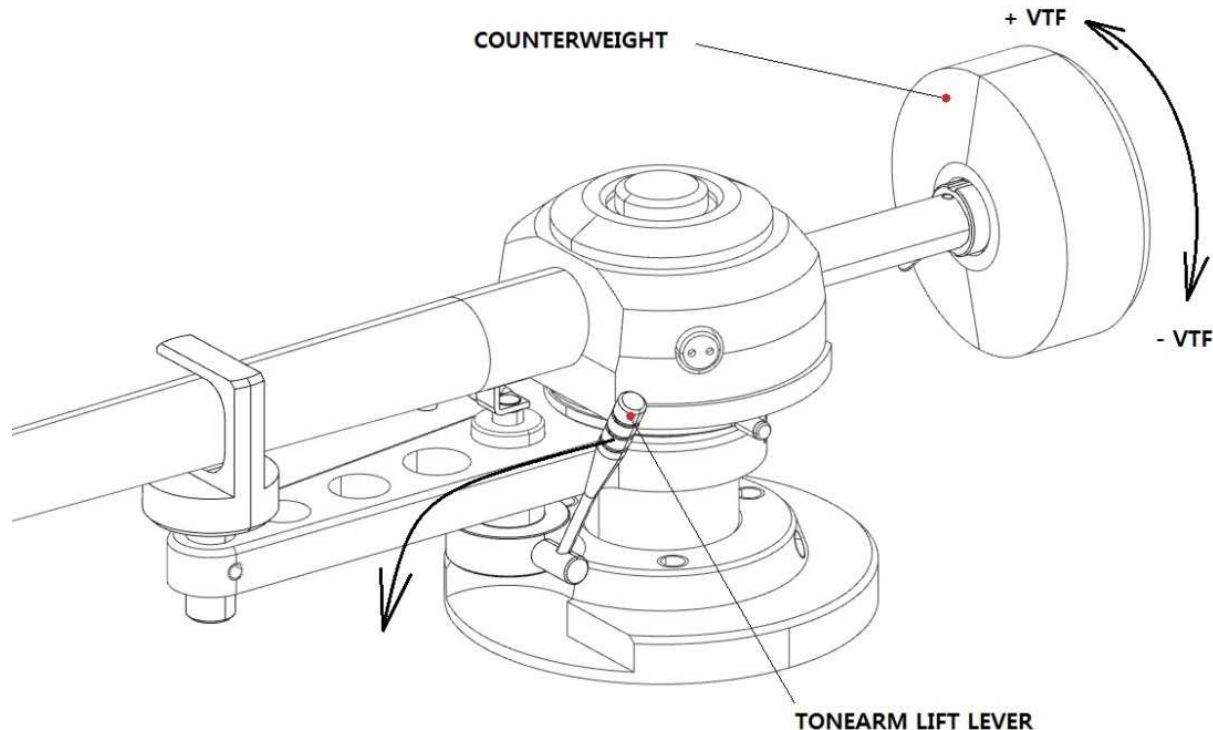

d) Tonearm output connection

Connect the tonearm cable provided with the accessories to the 5-pin tonearm connector that is located at the base of the tonearm. To avoid damaging your tonearm, make sure to align the connector pins in the proper position!

e) Vertical Tracking Angle setting (VTA)

To set the Vertical Tracking Angle, first put a record on the platter. When the needle is lowered into the record groove, the tube of the tonearm should be parallel to the surface of the record. If it is not, loosen both hexagonal screws in the tonearm base just enough to allow vertical movement of the arm pillar without force, and slide the arm up or down until it is parallel.

Carefully and evenly retighten the hexagon screws *without applying excessive force* (which could deform the arm pillar).

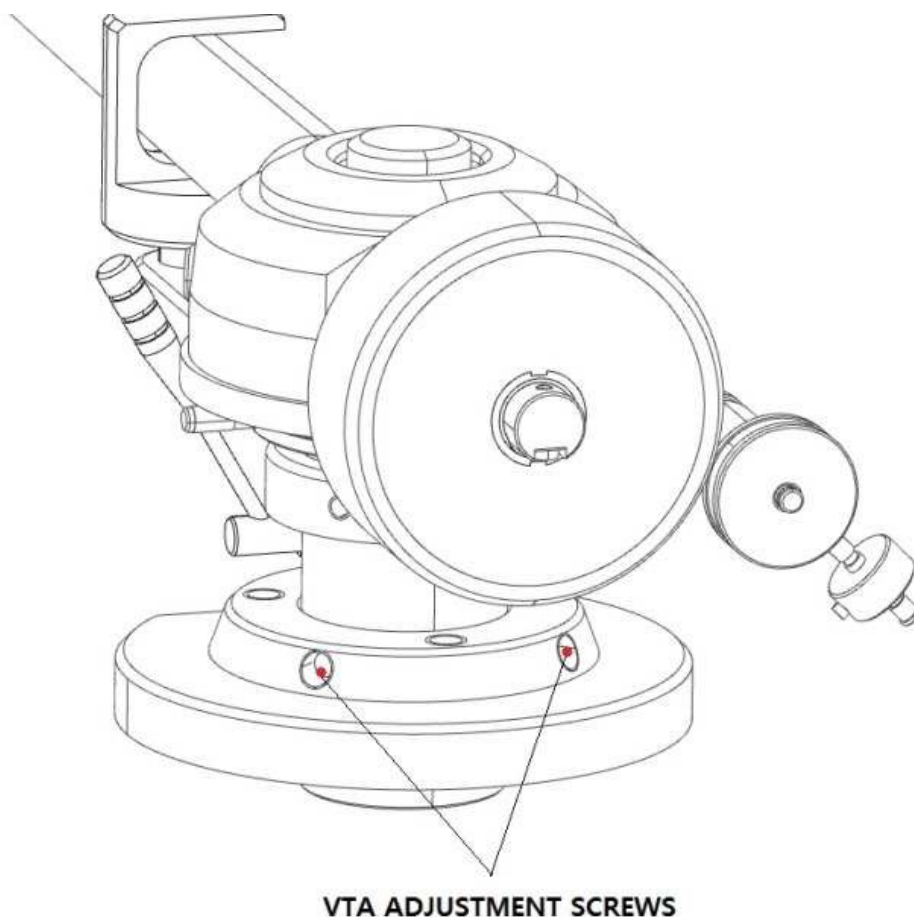

f) Azimuth setting

The cartridge needle must be perpendicular to the record in order to trace the groove wall modulations correctly.

The azimuth (angle) is precisely set by the factory. In the event that you need to modify this setting, however, follow the instructions below.

!! DO NOT REMOVE THE AZIMUTH SET SCREW COMPLETELY!

Loosen the screw just enough to be able to gently rotate the arm tube and set the azimuth to the correct position. The correct position can be checked from the front view, preferably with the needle placed on a mirror placed on the platter. Once the azimuth setting is correct, gently re-tighten the AZIMUTH SETTING SCREW.

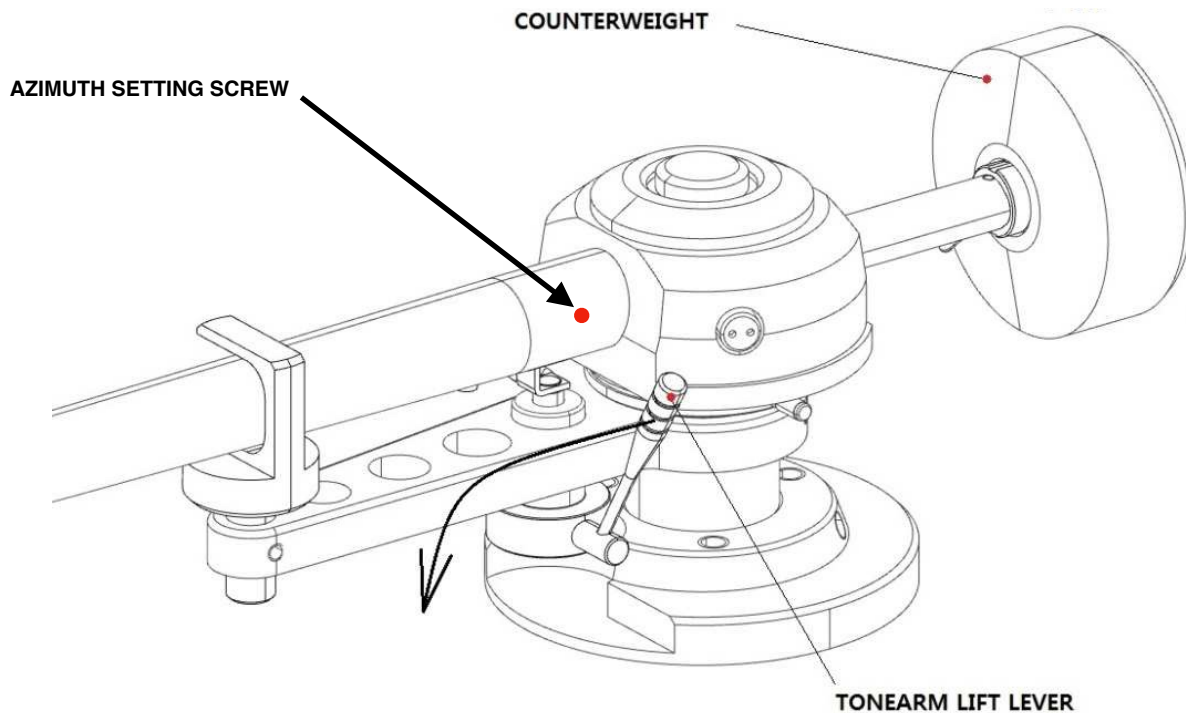

Examples of incorrect azimuth setup:

Too much left angle:

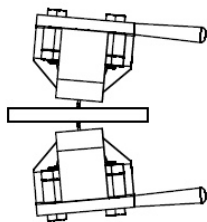

Too much right angle:

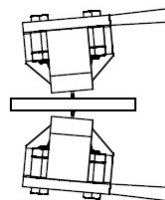

The correct position is 100% perpendicular to the record.

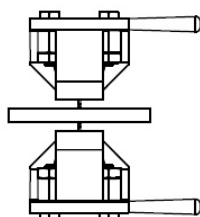

g) Anti-skating assembly and adjustment

The anti-skating mechanism is shipped partially disassembled to avoid damage during transport. For correct installation, please follow the steps below.

Step 1:

Prepare all parts supplied from the accessories bag:

- Anti-skating sliding mechanism with anti-skating weight and thread for mounting on the tonearm
- Anti-skating support rod

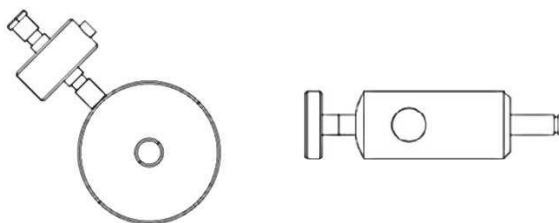

Step 2:

Put the anti-skating support rod on the shaft mounted on the side of the tonearm so that it is parallel to the sub-chassis, as pictured in the illustration below. Then tighten the screw to prevent movement on the shaft.

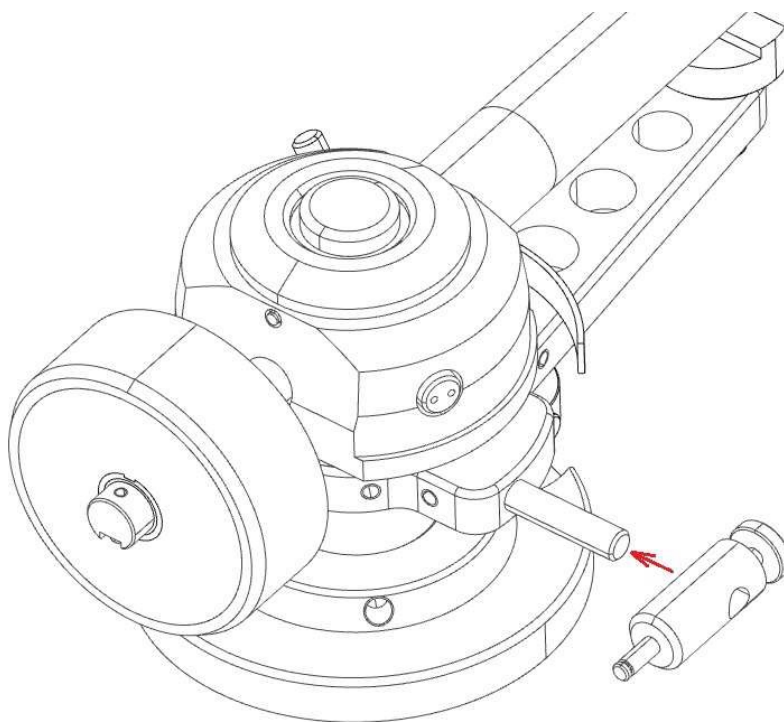

Step 3:

The anti-skating sliding mechanism is supplied with a pre-mounted anti-skating weight and antiskating thread. Put the eye of the anti-skating thread around the hole for the HOOK SCREW and screw the HOOK SCREW into the tonearm through the eye of the anti-skating thread as shown in the illustration below.

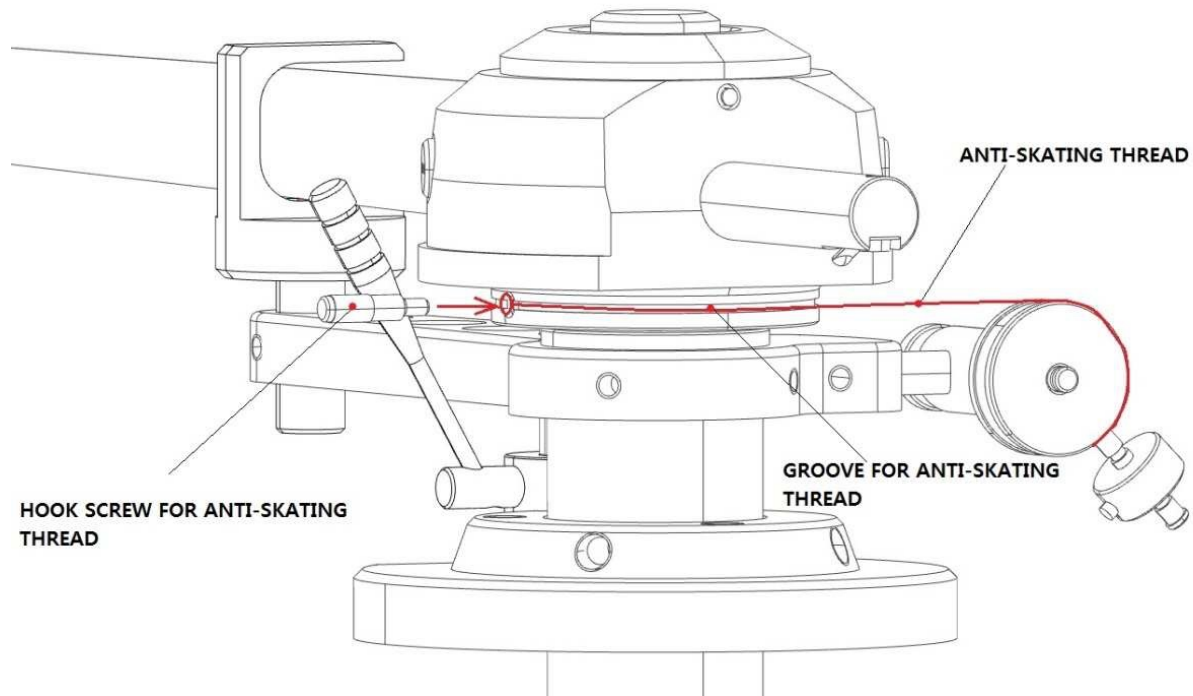

Step 4:

Put the anti-skating sliding mechanism on the end of the anti-skating support rod. The antiskating thread should fit into the groove in the tonearm.

!! Be careful when handing the anti-skating thread in order to avoid damaging it.

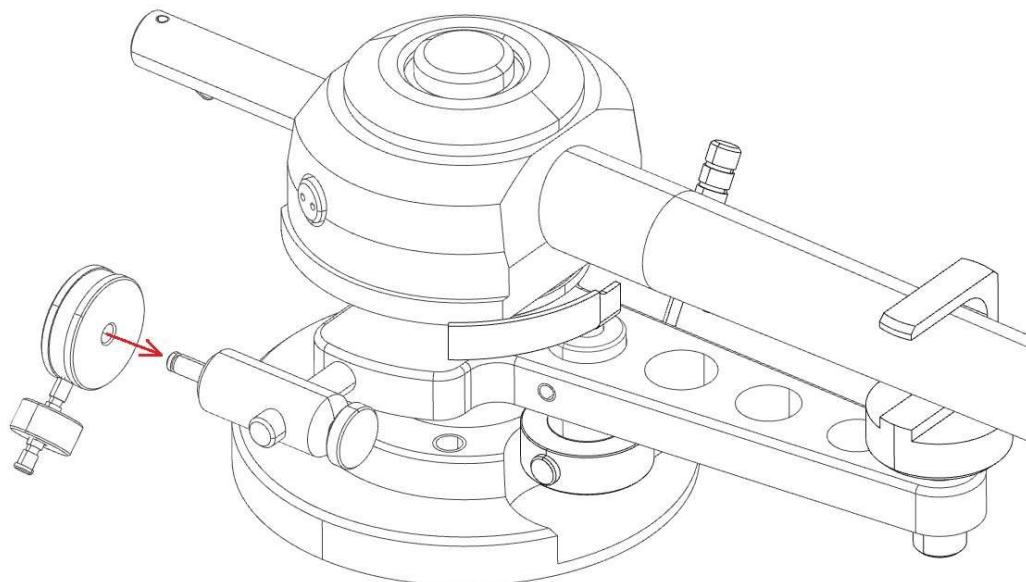

Step 5:

Anti-skating force adjustment

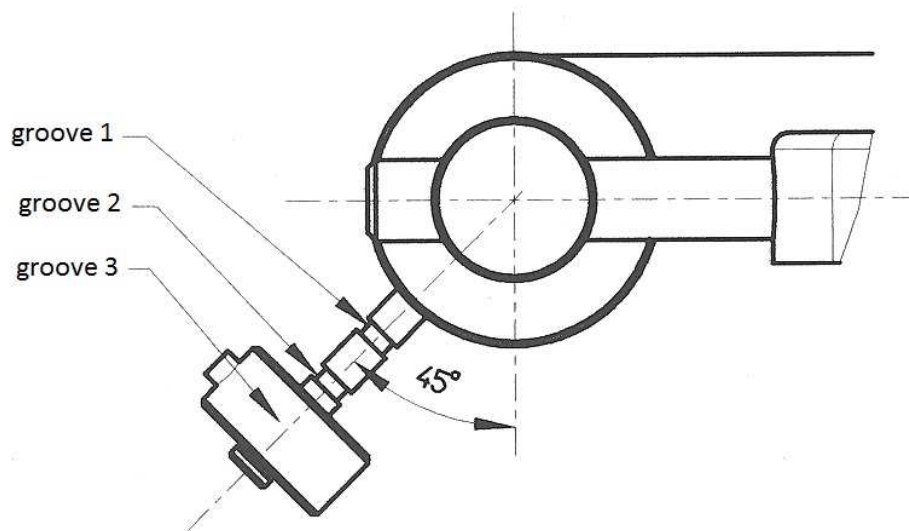

Adjust the anti-skating force by positioning the weight on the appropriate groove of the antiskating sliding mechanism. Anti-skating downforce should be adjusted in correspondence with the tonearm downforce as follows:

Tonearm downforce:

Lower than 13 mN or 1.3 grams
13–18 mN or 1.3–1.8 grams
18–25 mN or 1.8–2.5 grams

Anti-skating groove:

1st groove from bearing
2nd groove from bearing
3rd groove from bearing

Arm Specifications

	12" C-Note	10" C-Note	9" C-Note
Effective tone arm mass	19.2 grams	16.5 grams	14.8 grams
Effective tone arm length	304.8 mm	254 mm	230 mm
Pivot to spindle distance	291.6 mm	238 mm	212 mm
Overhang	13.2 mm	16 mm	18 mm
Offset angle	18°	21.4°	24°
Max null point	125 mm	126.8 mm	130.6 mm
Min null point	251.7 mm	248.2 mm	243.7 mm